

# AC563G1

## USB 3.0 / 3.1 Gen1 Active Paddle Card for Micro-B

### Introduction

AC563G1 is a high performance active paddle card for USB 3.0/3.1 Gen1 up to 5Gbps and features a continuous time linear equalizer (CTLE) to provide a boost up to +11.6 dB. It opens an input eye due to inter-symbol interference (ISI) induced by long distance cable or thin wire cable.

### Feature

- Supported USB Standard : USB 3.0 / USB3.1 Gen1 up to 5Gbps
- Interface Connector : Micro-B PLUG & Cable soldering PAD
- Redriver IC : THCX222R05, THine Electronics, Inc.
- Adjustable Gain : 8 levels setting by resistors up to +11.6dB (default +6.7dB)
- Power Supply : VBUS (5V)
- Power Consumption : 0.4W typical, Ultra Low-Power Architecture
- Temperature Range : 0°C to 70°C
- Module Size : width 12mm \* length 29mm

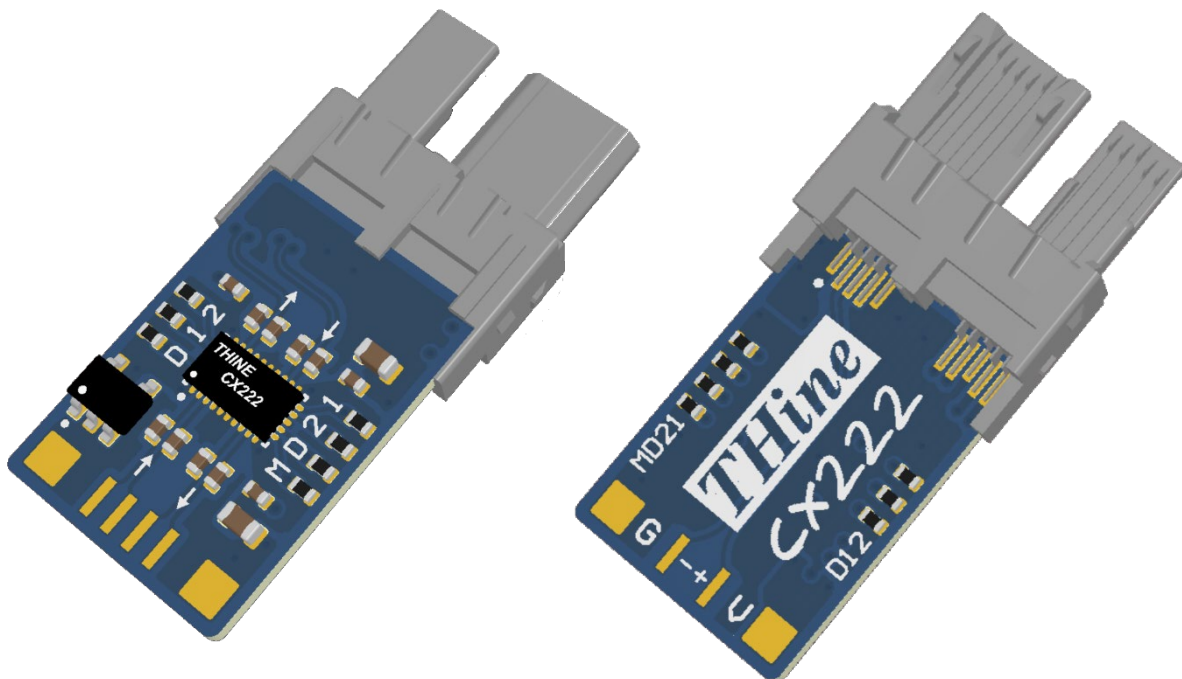

## Block Diagram

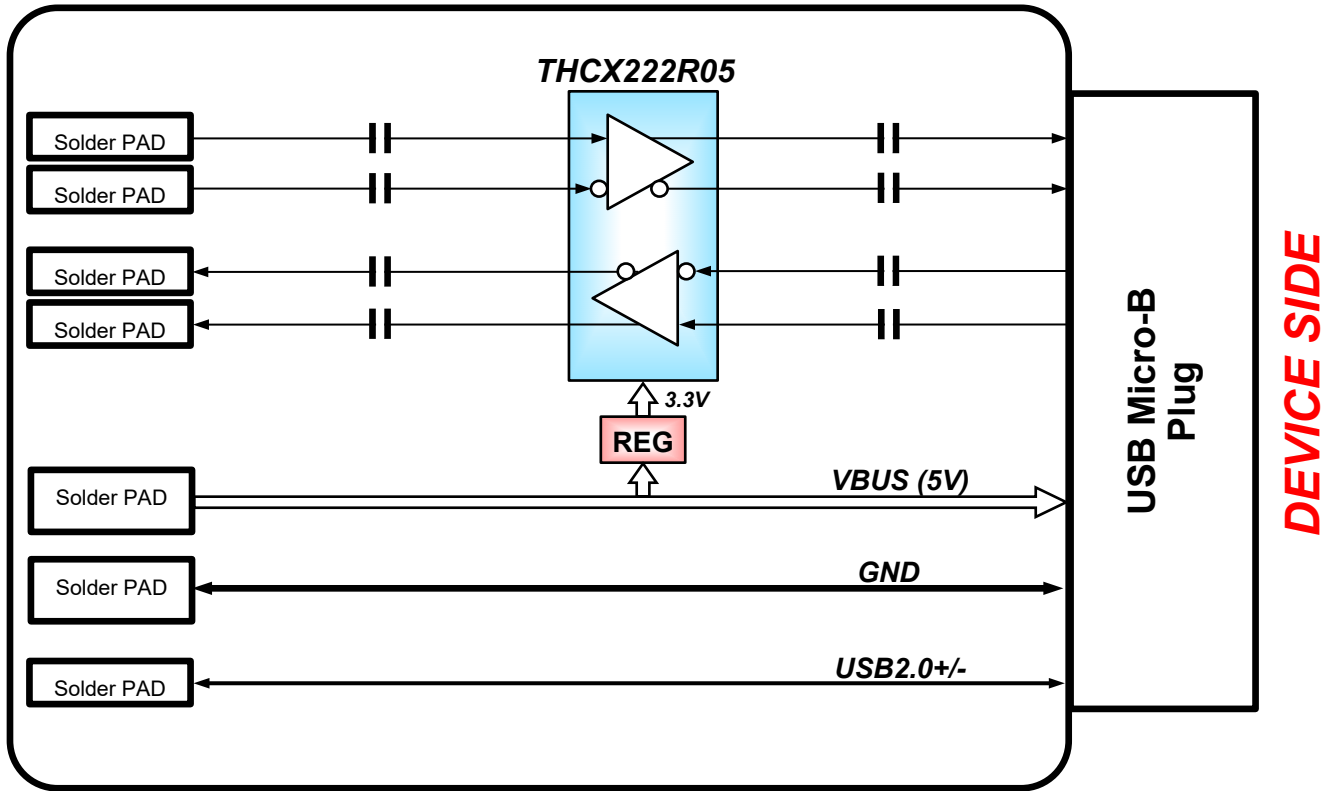

## Condition

	Specification
<b>Model</b>	AC563G1
<b>Supply Voltage</b>	VBUS DC5V±10%
<b>Power Consumption</b>	0.4W Typ. (Reference data)
<b>Operating Temperature</b>	0°C~70°C
<b>Storage Temperature</b>	-40°C~125°C
<b>Flammability</b>	UL94V-0
<b>Module Size</b>	12mm * 29mm
<b>PCB Color</b>	Blue

## How to use

Please solder your twist pair cable to AC563G1. It recovers attenuated signal via the cable.  
Default equalizer setting is +6.7dB and it will recover attenuated signal by about 8m of AWG32 cable.  
Please adjust equalizer level against the cable characteristics.

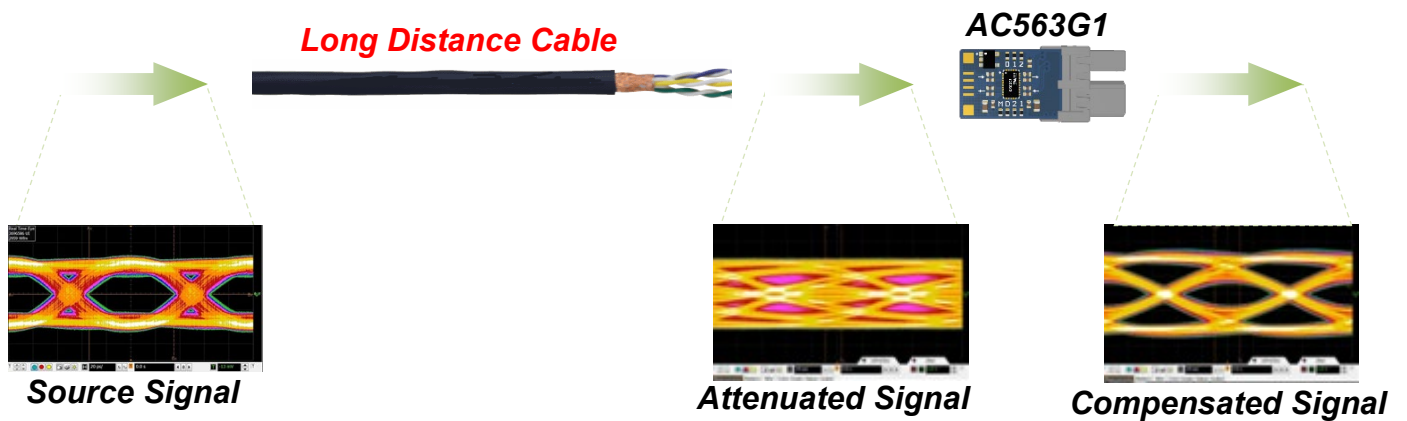

## Cable Soldering PAD & Resistor

Positions of cable soldering PAD and resistor are indicated as below.

AC563G1 has two kinds of gain setting (AC GAIN & DC GAIN) for each channel TX/RX.

Below resistors change the gain level.

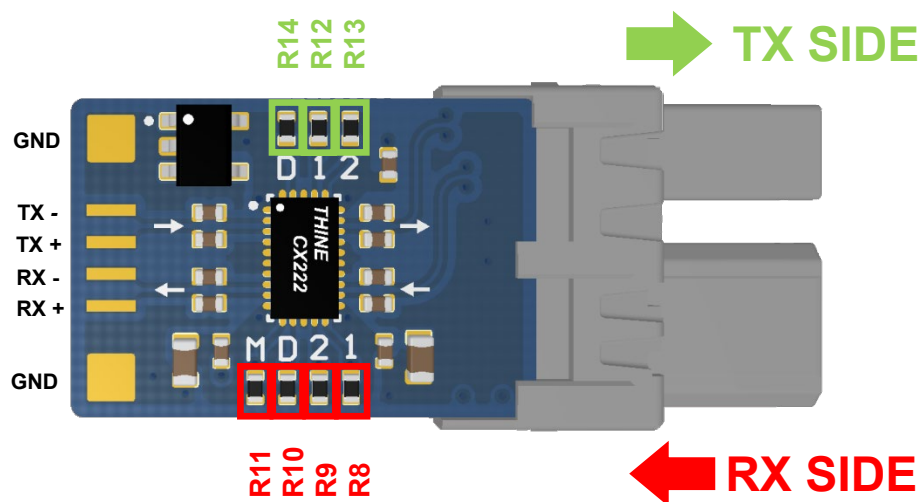
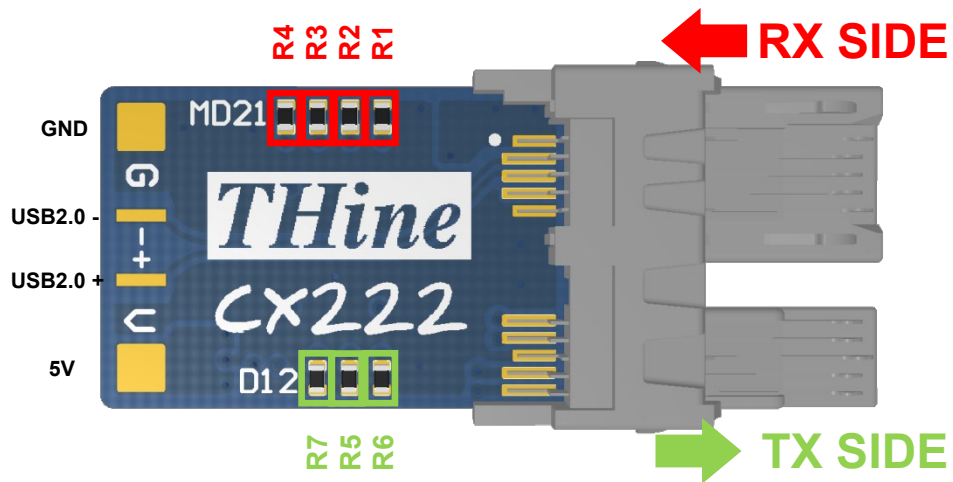

## AC562G1 & AC563G1 Wiring

Wiring between AC563G1 and AC563G1 is indicated as below.

### TOP SIDE Wiring

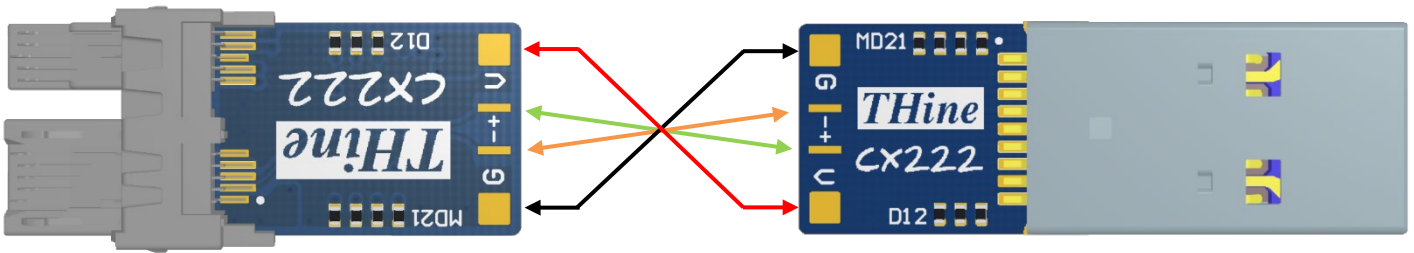

### BOTTOM SIDE Wiring

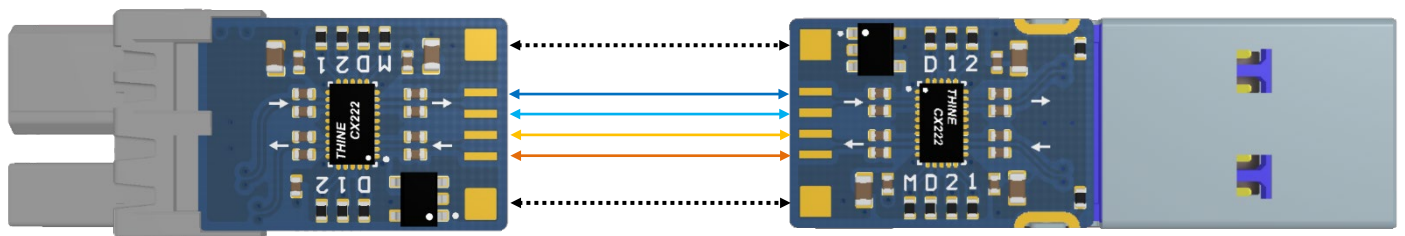

## AC GAIN

AC GAIN is a function to recover high frequency characteristics of USB signal.

Please adjust the AC GAIN to open eye diagram enough by 8 levels gain settings as below.

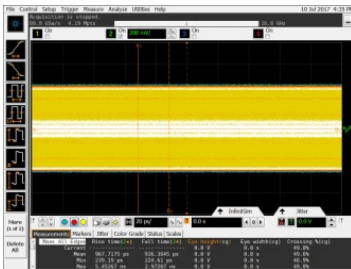

Input signal

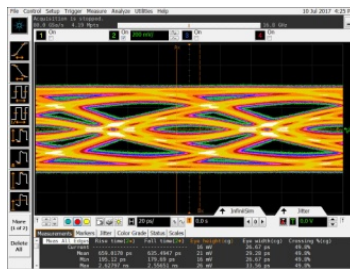

AC Gain : +3.7dB  
(LEVEL 3)

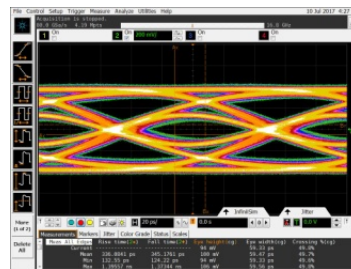

AC Gain : +5.6dB  
(LEVEL 5)

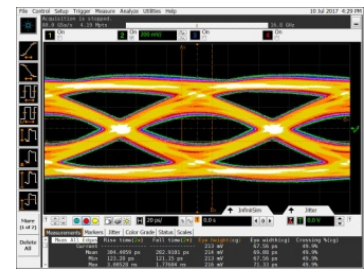

AC Gain : +8.0dB  
(LEVEL 7)

### SETTING TABLE for AC GAIN

LEVEL	GAIN [dB]	TX				RX			
		R5	R6	R12	R13	R1	R2	R8	R9
1	1.5	0	0	N.C.	N.C.	0	0	N.C.	N.C.
2	2.7	180k	0	N.C.	N.C.	180k	0	N.C.	N.C.
3	3.7	N.C.	0	N.C.	N.C.	N.C.	0	N.C.	N.C.
4	4.8	N.C.	0	0	N.C.	N.C.	0	0	N.C.
5	5.6	0	180k	N.C.	N.C.	0	180k	N.C.	N.C.
6	<b>6.7</b>	<b>180k</b>	<b>180k</b>	<b>N.C.</b>	<b>N.C.</b>	<b>180k</b>	<b>180k</b>	<b>N.C.</b>	<b>N.C.</b>
7	8.0	N.C.	180k	N.C.	N.C.	N.C.	180k	N.C.	N.C.
8	8.9	N.C.	180k	0	N.C.	N.C.	180k	0	N.C.

N.C : Not Connected

(default : LEVEL-6)

# DC GAIN

DC GAIN is an adjustment function for DC LEVEL.  
 Please adjust the DC GAIN level to be eye-shaped diagram.  
 Recommendation setting is level-2 or level-3.

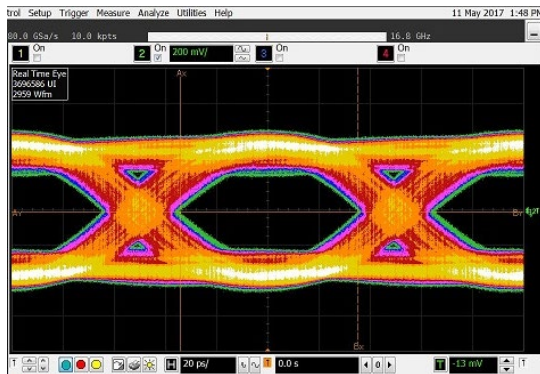

**DC GAIN : +0.1dB  
(LEVEL 3)**

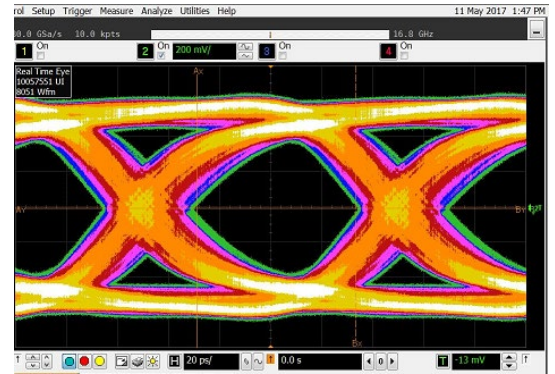

**DC GAIN : +4dB  
(LEVEL 4)**

## SETTING TABLE for DC GAIN

LEVEL	DC Gain [dB]	TX		RX	
		R7	R14	R3	R10
1	-2.2	0Ω	N.C	0Ω	N.C
2	-1.3	180kΩ	N.C	180kΩ	N.C
3	<b>+0.1</b>	<b>N.C</b>	<b>N.C</b>	<b>N.C</b>	<b>N.C</b>
4	+4.1	N.C	0Ω	N.C	0Ω

(Default : LEVEL-3)

## DETECTION MODE

AC563G1 has two detection mode, SIGNAL-DETECT and RX-DETECT.

SIGNAL-DETECT detects input signal level.

The channel's input signal level determines whether the output is active.

RX-DETECT is automatic receiver detect function.

It will move to low power mode due to inactivity if receiver is not detected.

Each channel operates each detection mode fully independently.

**SETTING TABLE for DETECTION MODE**

<b>SETTING</b>	<b>MODE</b>	<b>R4</b>
<b>1</b>	RX-DETECT Enable, SIGNAL-DETECT Enable	0
<b>2</b>	RX-DETECT Enable, SIGNAL-DETECT Disable	180k
<b>3</b>	<b>RX-DETECT Disable, SIGNAL-DETECT Disable</b>	<b>N.C</b>

(default : SETTING-3)



## Simulation Result for “Frequency Response”

A simulation result of “frequency response” is indicated as below.

X-AXIS is FREQUENCY [unit:MHz] and Y-AXIS is MAGNITUDE [unit:dB].

“**Insertion Loss**” is an attenuation characteristics of cable and “**Gain Curve**” is an amplitude characteristic of AC563G1.

On the other hand, “**Compensated Curve**” indicates a compensated characteristics of 5m cable. It is an addition result of “Insertion Loss” and “Gain Curve”.

The compensated curve is flat characteristics until 5Gbps frequency range and it indicates the compensated cable can transmit signal without loss.

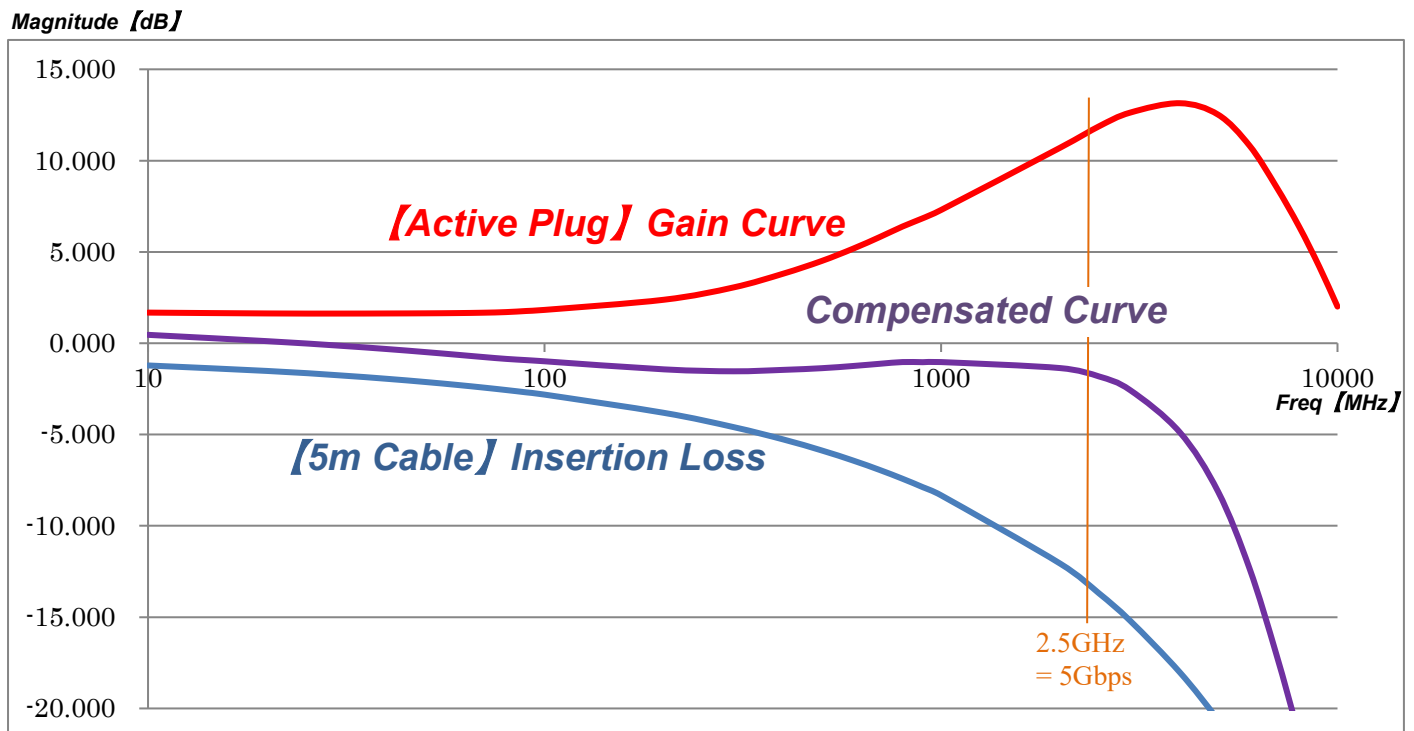

## Notices and Requests

Please kindly read, understand and accept this “Notices and Requests” before using this product.

### For the Material:

1. The product specifications described in this material are subject to change without prior notice.
2. The circuit diagrams described in this material are examples of the application which may not always apply to design of respective customers. THine Electronics, Inc. (“THine”) is not responsible for possible errors and omissions in this material. Please note even if the errors or omissions should be found in this material, THine may not be able to correct them immediately.
3. This material contains THine’s copyright, know-how or other proprietary. Copying or disclosing of the contents of this material to any third party without THine’s prior permission is strictly prohibited.

### For the Product:

1. This product is solely designed for evaluation purpose, and other purposes including mass production and distribution are not intended.
2. This product has been solely manufactured for electric design engineers but not for end-users.
3. This product is not radiation-tolerant product.
4. This product is presumed to be used for general electric device, not for applications which require extremely high-reliability/safety (including medical device concerned with critical care, aerospace device, or nuclear power control device). Also, when using this product for any device concerned with control and/or safety of transportation means, traffic signal device, or other various types of safety device, such use must be after applying appropriate measures to the product.
5. This product has been designed with the utmost care to accomplish the purpose of evaluation of IC products manufactured by THine Electronics, Inc. (“THine”); however, THine MAKES NO WARRANTIES OR REPRESENTATIONS WITH REGARD TO ANY PERFORMANCE OR FUNCTION OF THIS PRODUCT IN ANY CIRCUMSTANCES.
6. This product has been manufactured with the utmost care in quality control and product reliability; however, there may be faults or defects with a low but fixed probability, as inevitable phenomenon concerned with semiconductor manufacturing processes. Therefore, customers are encouraged to have sufficiently redundant or error-preventive design applied to the use of the product so as not to have THine’s product cause any social or public damage. Neither replacement nor failure analysis of the product is available in any case of defects with the product and/or the product’s components.
7. Customers are asked, if required, to judge by themselves on whether this product falls under the category of strategic goods under the Foreign Exchange and Foreign Trade Act.
8. Please Note that even if infringement of any third party’s industrial ownership should occur by using this product, THine will be exempted from any responsibility unless it directly relates to the production process or functions of the product.
9. Developing, designing and manufacturing of customers’ own products, equipment or system by using of this product is strictly prohibited in any way.

***THine Electronics, Inc.***

[THine@cel.com](mailto:THine@cel.com)